

Request For Quotation

Order the parts you need from our real-time inventory database. Simply complete a request for quotation form with your part information and a sales representative will respond to you with price and availability.

[Request For Quotation](#)

Your free datasheet starts on the next page.

More datasheets and data books are available from our homepage: <http://www.datasheetarchive.com>

Description

The μPD765A/B is an LSI floppy disk controller (FDC) chip which contains the circuitry and control functions for interfacing a processor to 4 floppy disk drives. It is capable of either IBM 3740 single density format (FM), or IBM System 34 double density format (MFM) including double-sided recording. The μPD765A/B provides control signals which simplify the design of an external phase-locked loop and write precompensation circuitry. The FDC simplifies and handles most of the burdens associated with implementing a floppy disk interface.

Hand-shaking signals are provided in the μPD765A/B which make DMA operation easy to incorporate with the aid of an external DMA controller chip, such as the μPD8257. The FDC will operate in either the DMA or non-DMA mode. In the non-DMA mode the FDC generates interrupts to the processor every time a data byte is to be transferred. In the DMA mode, the processor need only load the command into the FDC and all data transfers occur under control of the FDC and DMA controllers.

There are 16 commands which the μPD765A/μPD765B will execute. Most of these commands require multiple 8-bit bytes to fully specify the operation which the processor wishes the FDC to perform. The following commands are available.

Read Data	Read Deleted Data
Read ID	Write Data
Specify	Write ID (Format Write)
Read Diagnostic	Write Deleted Data
Scan Equal	Seek
Scan High or Equal	Recalibrate
Scan Low or Equal	Sense Interrupt Status
Version	Sense Drive Status.

Ordering Information

Device Number	Package Type	Max Freq. of Operation
μPD765AC2	40-pin plastic DIP	8 MHz
μPD765B	40-pin plastic DIP	8 MHz

Features

Address mark detection circuitry is internal to the FDC which simplifies the phase-locked loop and read electronics. The track stepping rate, head load time, and head unload time are user-programmable. The μPD765A/μPD765B offers additional features such as multi-track and multi-side read and write commands and single and double density capabilities.

- FM, MFM Control
- Variable recording length: 128, 256, . . . 8192 bytes/sector
- IBM-compatible format (single- and double-sided, single- and double-density)
- Multi-sector and multi-track transfer capability
- Drive up to 4 floppy or micro floppydisk drives
- Data scan capability — will scan a single sector or an entire cylinder comparing byte-for-byte host memory and disk data
- Data transfers in DMA or non-DMA mode
- Parallel seek operations on up to four drives
- Compatible with μPD8080/85, μPD8086/88, V-series and μPD780 (Z80®) microprocessors
- Single-phase clock: 8 MHz maximum
- +5 V only

* Z80 is a registered trademark of the Zilog Corporation.

Pin Configuration

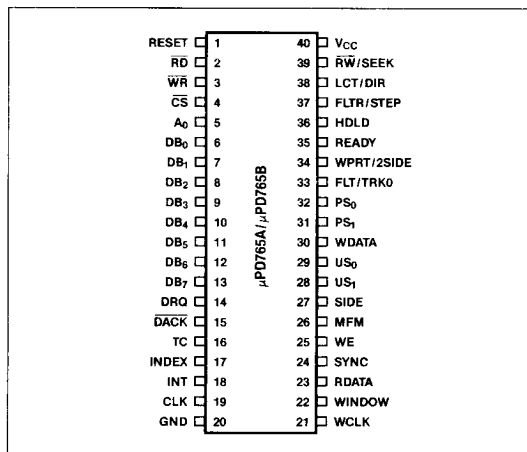

Pin Identification

No.	Symbol	Function
1	RESET	Reset input
2	\overline{RD}	Read control input
3	\overline{WR}	Write control input
4	\overline{CS}	Chip select input
5	A_0	Data or status select input
6-13	DB_0 - DB_7	Bidirectional data bus
14	DRQ	DMA request output
15	\overline{DACK}	DMA acknowledge input
16	TC	Terminal count input
17	INDEX	Index input
18	INT	Interrupt request output
19	CLK	Clock input
20	GND	Ground
21	WCLK	Write clock input
22	WINDOW	Read data window input
23	RDATA	Read data input
24	SYNC	VCO sync output
25	WE	Write enable output
26	MFM	MFM output
27	SIDE	Head select output
28, 29	US_0 , US_1	FDD unit select output
30	WDATA	Write data output
31, 32	PS_0 , PS_1	Preshift output
33	FLT / TRK0	Fault / track zero input
34	WPRT / 2SIDE	Write protect / two side input
35	READY	Ready input
36	HDLD	Head load output
37	FLTR / STEP	Fault reset / step output
38	LCT / DIR	Low current direction output
39	\overline{RW} / SEEK	Read / write / seek output
40	V_{CC}	DC power (+5V)

Pin Functions

RESET (Reset)

The RESET input places the FDC in the idle state. It resets the output lines to the FDD to 0 (low), except PS_0 , 1 and WDATA (undefined), INT and DRQ also go low; DB_0 -7 goes to an input state. It does not affect SRT, HUT, or HLT in the Specify command. If the RDY input is held high during reset, the FDC will generate an interrupt within 1.024ms. To clear this interrupt, use the Sense Interrupt Status command.

\overline{RD} (Read Strobe)

The RD input allows the transfer of data from the FDC to the data bus when low and either \overline{CS} or \overline{DACK} is asserted.

\overline{WR} (Write Strobe)

The \overline{WR} input allows the transfer of data to the FDC from the data bus when low. Disabled when \overline{CS} is high.

A_0 (Data / Status Select)

The A_0 input selects the data register ($A_0 = 1$) or status register ($A_0 = 0$) contents to be accessed through the data bus.

\overline{CS} (Chip Select)

The FDC is selected when \overline{CS} is low, enabling \overline{RD} and \overline{WR} .

DB_0 - DB_7 (Data Bus)

DB_0 - DB_7 are a bidirectional 8-bit data bus. Disabled when \overline{CS} is high.

DRQ (DMA Request)

The FDC asserts the DRQ output high to request a DMA transfer.

\overline{DACK} (DMA Acknowledge)

When the \overline{DACK} input is low, a DMA cycle is active and the controller is performing a DMA transfer.

TC (Terminal Count)

When the TC input is high, it indicates the termination of a DMA transfer. It terminates data transfer during Read/Write/Scan commands in DMA or interrupt mode.

INDEX (Index)

The INDEX input goes high at the beginning of a disk track.

INT (Interrupt)

The INT output is FDC's interrupt request. In Non-DMA mode, the signal is output for each byte. In DMA mode, it is output at the termination of a command operation.

CLK (Clock)

CLK is the input for the FDC's single-phase, TTL-level squarewave clock: 8 MHz or 4 MHz. (Requires a pull-up resistor.)

WCLK (Write Clock)

The WCLK input sets the data write rate to the FDD. It is 500 kHz for FM, 1 MHz for MFM drives, for 8 MHz operation of the FDC; 250 kHz FM or 500 kHz MFM for 4 MHz FDC operation.

This signal must be input for read and write cycles. WCLK's rising edge must be synchronized with CLK's rising edge, except for the μPD765B.

WINDOW (Read Data Window)

The WINDOW input is generated by the phase-locked loop (PLL). It is used to sample data from the FDD and in distinguishing between clock and data bits in the FDC.

RDATA (Read Data)

The RDATA input is the read data from the FDD, containing clock and data bits. To avoid a deadlock situation, input RDATA and WINDOW together.

WDATA (Write Data)

WDATA is the serial clock and data output to the FDD.

WE (Write Enable)

The WE output enables write data into the FDD.

SYNC (VCO Sync)

The SYNC output inhibits the VCO in the PLL when low, enables it when high.

MFM (MFM Mode)

The MFM output shows the VCO's operation mode. It is high for MFM, low for FM.

SIDE (Head Select)

Head 1 is selected when the SIDE output is 1 (high), head 0 is selected when SIDE is 0 (low).

US₀, US₁ (Unit Select 0, 1)

The US₀ and US₁ outputs select up to 4 floppy disk drive units using an external decoder.

PS₀, PS₁ (Preshift 0, 1)

The PS₀ and PS₁ outputs are the write precompensation request signals for MFM mode. They determine early, late, and normal times for WDATA shifting.

PS0	PS1	Shift (MFM WDATA)
0	0	Normal
0	1	Late
1	0	Early
1	1	—

READY (Ready)

The READY input indicates that the FDD is ready to receive data.

HDL (Head Load)

The HDL output is the command which causes the read/write head in the FDD to contact the diskette.

FLT/TRK0 (Fault/Track 0)

In the read/write mode, the FLT input detects FDD fault conditions. In the seek mode, TRK0 indicates track 0 head position.

WPRT/2SIDE (Write Protect/Two Side)

In the read/write mode, the WPRT input senses write protected status (at the drive or media.) In the seek mode, 2SIDE senses two-sided media.

FLTR/STEP (Fault Reset/Step)

In the read/write mode, the FLTR output resets the fault flip-flop in the FDD. In the seek mode, STEP outputs step pulses to move the head to another cylinder. A fault reset pulse is issued at the beginning of each Read or Write command prior to the HDL signal.

LCT/DIR (Low Current/Direction)

In the read/write mode, the LCT output indicates that the R/W head is positioned at cylinder 42 or greater. In the seek mode, the DIR output determines the direction the head will move in when it receives a step pulse. If DIR is 0, seeks are performed in the outward direction; DIR is 1, seeks are performed in the inward direction.

R \bar{W} /SEEK (Read/Write/Seek)

The R \bar{W} /SEEK output specifies the read/write mode when low, and the seek mode when high.

GND (Ground)

Ground.

V_{CC} (+5 V)

+5 V power supply.

Block Diagram

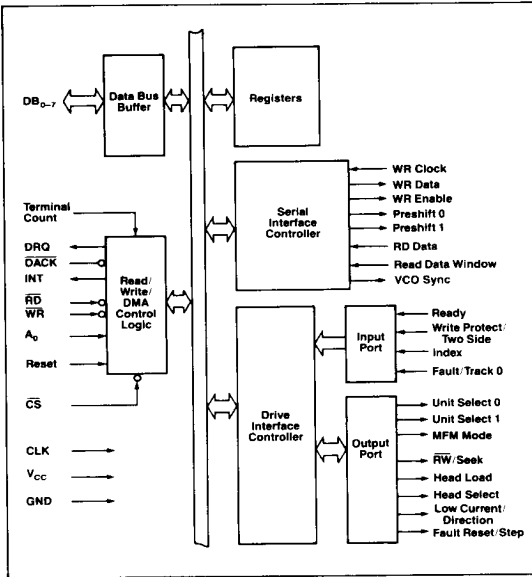

Absolute Maximum Ratings

$T_A = 25^\circ\text{C}$

Power supply voltage, V_{CC}	-0.5 to +7 V
Input voltage, V_I	-0.5 to +7 V
Output voltage, V_O	-0.5 to +7 V
Operating temperature, T_{OP}	-10°C to +70°C
Storage temperature, T_{STG}	-65°C to +150°C

Comment: Exposing the device to stresses above those listed in the Absolute Maximum Ratings could cause permanent damage. The device should not be operated under conditions outside the limits described in the operational sections of this specification. Exposure to absolute maximum rating conditions for extended periods may affect device reliability.

DC Characteristics

$T_A = -10^\circ\text{C}$ to $+70^\circ\text{C}$, $V_{CC} = +5\text{V} \pm 10\%$

Parameter	Symbol	Limits			Unit	Test Conditions
		Min	Typ	Max		
Input voltage low	V_{IL}	-0.5		+0.8	V	
Input voltage high	V_{IH}	2.0		$V_{CC} + 0.5$	V	
Output voltage low	V_{OL}			0.45	V	$I_{OL} = 2.0\text{ mA}$
Output voltage high	V_{OH}	2.4		V_{CC}	V	$I_{OH} = -200\text{ }\mu\text{A}$
Input voltage low (CLK + WCLK)	$V_{IL}(\Phi)$	-0.5		0.65	V	
Input voltage high (CLK + WCLK)	$V_{IH}(\Phi)$	2.4		$V_{CC} + 0.5$	V	
Supply current (V_{CC})	I_{CC}			150	mA	$\mu\text{PD765AC2}$
				140	mA	μPD765B
Input load current high	I_{LH}			10	μA	$V_{IN} = V_{CC}$
Input load current low	I_{LL}			-10	μA	$V_{IN} = 0\text{ V}$
Output leakage current high	I_{LOH}			10	μA	$V_{OUT} = V_{CC}$
Output leakage current low	I_{LOL}			-10	μA	$V_{OUT} = +0.45\text{ V}$

Capacitance

$T_A = 25^\circ\text{C}$, $f_C = 1\text{ MHz}$, $V_{CC} = 0\text{ V}$

Parameter	Symbol	Limits			Unit	Test Conditions
		Min	Typ	Max		
Input clock capacitance	$C_{IN}(\Phi)$			20	pF	(Note 1)
Input capacitance	C_{IN}			10	pF	(Note 1)
Output capacitance	C_{OUT}			20	pF	(Note 1)

Note:

(1) All pins except pin under test tied to AC ground.

DIFFERENCES BETWEEN μPD765A AND μPD765B

The μPD765B is a functionally enhanced version of the μPD765A. Differences are explained below.

Overrun Bit [OR]

In μPD765A, when executing a read- or write-type command (except READ ID and SCAN types), the result status OR bit is not set if there is an overrun on the final byte of a sector. An improvement in the μPD765B allows it to set the OR bit in any situation.

DRQ Reset

When an overrun occurs, the μPD765A needs $\overline{\text{DACK}}$ input to reset DRQ. If $\overline{\text{DACK}}$ is not available, an external DMA controller continues to operate even after the FDC enters the R-Phase (Result Phase), and stored result status may be transferred accidentally as ordinary data.

On the other hand, the μPD765B resets DRQ automatically just before the R-Phase entry and independent of the $\overline{\text{DACK}}$ input. See AC Characteristics for DRQ reset timing.

Clock Synchronization

The μPD765B does not require synchronization between the CLK and WCLK inputs.

Version Command

The Version command distinguishes the μPD765B from other devices. The ST0 response to the Version command is:

<u>Part No.</u>	<u>ST0 Value</u>
μPD765A	80H
μPD765B	90H

μ PD765A/ μ PD765B

AC Characteristics

$T_A = -10$ to $+70^\circ\text{C}$; $V_{CC} = +5\text{ V} \pm 10\%$

Parameter	Symbol	Min	Typ (1)	Max	Unit	Conditions
Clock period	ϕ_{CY}	120	125	500	ns	8-MHz CLK
		240	250	500	ns	4-MHz CLK
Clock active (high, low)	ϕ_0	40			ns	
Clock rise time	ϕ_R			20	ns	
Clock fall time	ϕ_F			20	ns	
$A_0, \overline{CS}, \overline{DACK}$ setup time to RD \downarrow	t_{AR}	0			ns	
$A_0, \overline{CS}, \overline{DACK}$ hold time from RD \uparrow	t_{RA}	0			ns	
RD width	t_{RR}	200			ns	
Data access time from RD \downarrow	t_{RD}			140	ns	$C_L = 100\text{ pF}$
DB to float delay time from RD \uparrow	t_{DF}	10		85	ns	
$A_0, \overline{CS}, \overline{DACK}$ setup time to WR \downarrow	t_{AW}	0			ns	
$A_0, \overline{CS}, \overline{DACK}$ hold time to WR \uparrow	t_{WA}	0			ns	
WR width	t_{WW}	200			ns	
Data setup time to WR \uparrow	t_{DW}	100			ns	
Data hold time from WR \uparrow	t_{WD}	0			ns	
INT delay time from RD \uparrow	t_{RI}			$2\phi_{CY} + \phi_0 + 135$	ns	Non-DMA mode
INT delay time from WR \uparrow	t_{WI}			$2\phi_{CY} + \phi_0 + 135$	ns	
DRQ cycle time	t_{MCY}	13			μs	$\phi_{CY} = 125\text{ ns}$ (Note 4)
$\overline{DACK} \downarrow \rightarrow \text{DRQ} \downarrow$ delay	t_{AM}			140	ns	
$\text{DRQ} \uparrow \rightarrow \overline{DACK} \downarrow$ delay	t_{MA}	200			ns	$\phi_{CY} = 125\text{ ns}$ (Note 4)
\overline{DACK} width	t_{AA}	$2\phi_{CY} + 15$			ns	
TC width	t_{TC}	1			ϕ_{CY}	
Reset width	t_{RST}	14			ϕ_{CY}	
DRQ $\downarrow \rightarrow$ INT response time	t_{MI}	60		77	ϕ_{CY}	μPD765B only
INT $\rightarrow \overline{DACK}$ ineffective	t_{IA}			1	ϕ_{CY}	

Parameter	Symbol	Min	Typ (1)	Max	Unit	Conditions
WCLK cycle time	t_{CY}		16		ϕ_{CY}	MFM = 0
			8		ϕ_{CY}	MFM = 1
WCLK active time (high)	t_0	80	250	350	ns	Note 4
CLK $\uparrow \rightarrow$ WCLK \downarrow delay	t_{CWL}	0		ϕ_0	ns	$\mu\text{PD765AC2}$ only
WCLK, RDATA and WINDOW rise time	t_R			20	ns	
WCLK, RDATA and WINDOW fall time	t_F			20	ns	
Preshift delay time from WCLK \uparrow	t_{CP}	20		100	ns	
WCLK $\uparrow \rightarrow$ WE \uparrow delay	t_{CWE}	20		100	ns	
WDATA delay time from WCLK \uparrow	t_{CD}	20		100	ns	
RDATA active time (high)	t_{RDD}	40			ns	
Window cycle time	t_{WCY}		2		μs	MFM = 0
			1		μs	MFM = 1
Window hold time from RDATA	t_{RDW}	15			ns	
Window setup time to RDATA	t_{WRD}	15			ns	
US _{0,1} setup time to SEEK \uparrow	t_{US}	12			μs	8-MHz CLK Notes 4, 5
SEEK setup time to DIR	t_{SD}	7			μs	
Direction setup time to step \uparrow	t_{DST}	1.0			μs	
US _{0,1} hold time from step \uparrow	t_{STU}	5.0			μs	
Step active time (high)	t_{STP}	6	7	8	μs	Notes 4, 5
Step cycle time	t_{SC}	33	Note 2	Note 2	μs	
Fault reset active time (high)	t_{FR}	8.0		10	μs	
Write data width	t_{WDD}	$t_0 - 50$			ns	
US _{0,1} hold time after seek	t_{SU}	15			μs	8-MHz CLK Notes 3, 4, 5
SEEK hold time from DIR	t_{DS}	30			μs	8-MHz CLK Notes 4, 5
DIR hold time after step	t_{STD}	24			μs	
Index pulse width	t_{IDX}	4			ϕ_{CY}	

AC Characteristics (cont)

Parameter	Symbol	Min	Typ [1]	Max	Unit	Conditions
RD ↓ delay from DRQ	t_{MR}	800			ns	8-MHz CLK Note 4
WR ↓ delay from DRQ	t_{MW}	250			ns	
WR ↑ or RD ↑ response time from DRQ ↑	t_{MRW}			12	μ s	

Notes:

- (1) Typical values for $T_A = 25^\circ\text{C}$ and nominal supply voltage.
- (2) Under software control. The range is from 1 ms to 16 ms at 8-MHz clock period, and 2 ms to 32 ms at 4-MHz clock period.
- (3) When one device is executing a SEEK operation, SENSE DRIVE STATUS is executed on another device.
- (4) Double these values for a 4-MHz clock period.
- (5) The drive side rating has a variance of -50 ns from the minimum value.

Timing Waveforms

Processor Read Operation

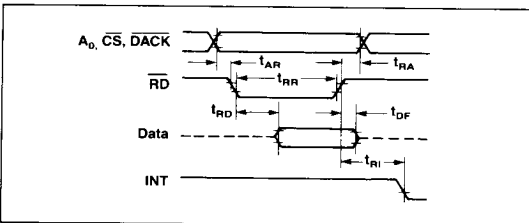

Processor Write Operation

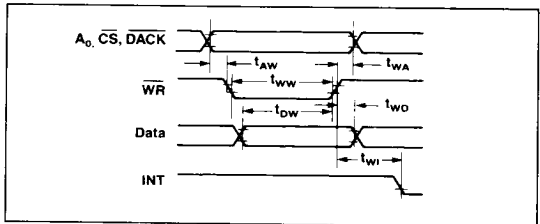

μ PD765A/ μ PD765B

Timing Waveforms (Cont)

Data Input Waveform for AC Test (Except CLK, WCLK)

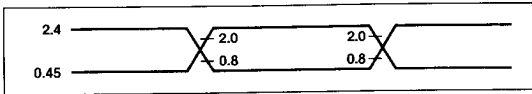

Clock (WCLK, CLK) Input Waveform for AC Test

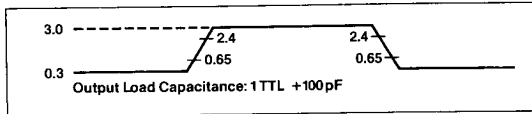

Clock

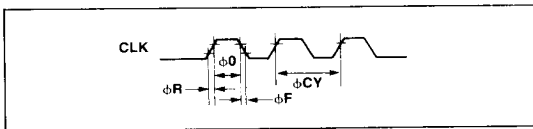

DMA Operation

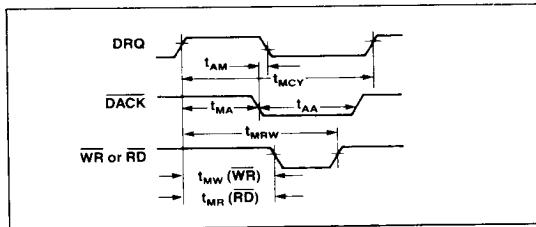

FDD Write Operation

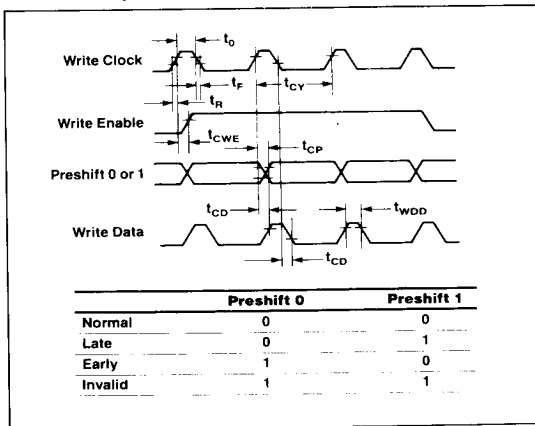

Seek Operation

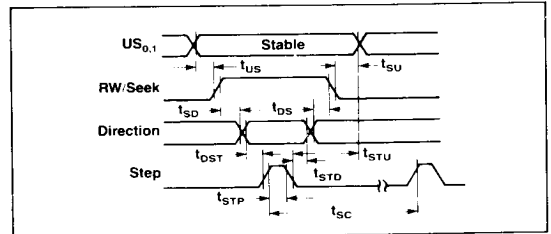

Overrun Operation (μ PD765B Only)

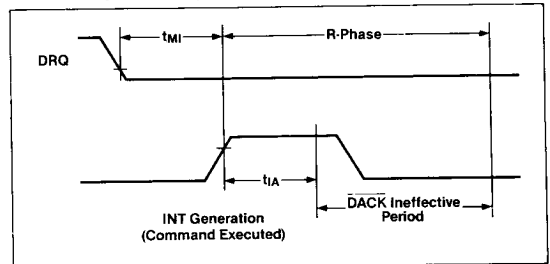

FLT Reset

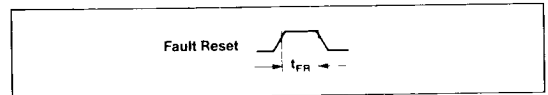

FDD Read Operation

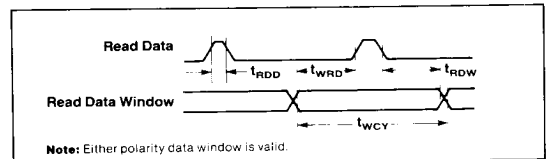

Terminal Count

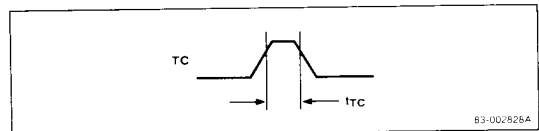

83-002826A

Reset

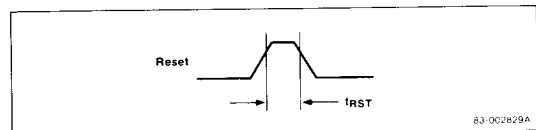

83-002829A

Timing Waveforms (Cont)

Write Clock

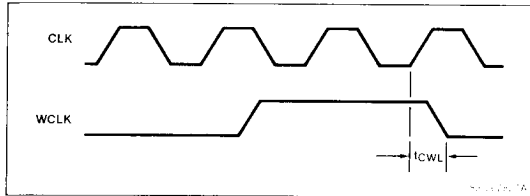

Index

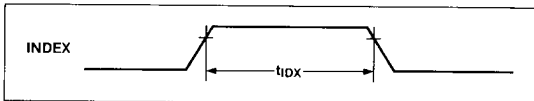

Internal Registers

The μPD765A/μPD765B contains two registers which may be accessed by the main system processor: a status register and a data register. The 8-bit main status register contains the status information of the FDC, and may be accessed at any time. The 8-bit data register (which actually consists of four registers, ST0-ST3, in a stack with only one register presented to the data bus at a time), stores data, commands, parameters, and FDD status information. Data bytes are read out of, or written into, the data register in order to program or obtain the results after a particular command (table 3). Only the status register may be read and used to facilitate the transfer of data between the processor and μPD765A/μPD765B.

The relationship between the status/data registers and the signals \overline{RD} , \overline{WR} , and A_0 is shown in table 1.

Table 1. Status/Data Register Addressing

A_0	\overline{RD}	\overline{WR}	Function
0	0	1	Read main status register
0	1	0	Illegal
0	0	0	Illegal
1	0	0	Illegal
1	0	1	Read from data register
1	1	0	Write into data register

The bits in the main status register are defined in table 2.

Table 2. Main Status Register

Pin		
No.	Name	Function
DB ₀	D ₀ B (FDD 0 Busy)	FDD number 0 is in the seek mode. If any of the D _n B bits is set FDC will not accept read or write command.
DB ₁	D ₁ B (FDD 1 Busy)	FDD number 1 is in the seek mode. If any of the D _n B bits is set FDC will not accept read or write command.
DB ₂	D ₂ B (FDD 2 Busy)	FDD number 2 is in the seek mode. If any of the D _n B bits is set FDC will not accept read or write command.
DB ₃	D ₃ B (FDD 3 Busy)	FDD number 3 is in the seek mode. If any of the D _n B bits is set FDC will not accept read or write command.
DB ₄	CB (FDC Busy)	A Read or Write command is in process. FDC will not accept any other command.
DB ₅	EXM (Execution Mode)	This bit is set only during execution phase in non-DMA mode. When DB ₅ goes low, execution phase has ended and result phase has started. It operates only during non-DMA mode of operation.
DB ₆	DIO (Data Input / Output)	Indicates direction of data transfer between FDC and data register. If DIO = 1, then transfer is from data register to the processor. If DIO = 0, then transfer is from the processor to data register.
DB ₇	RQM (Request for Master)	Indicates data register is ready to send or receive data to or from the processor. Both bits DIO and RQM should be used to perform the hand-shaking functions of "ready" and "direction" to the processor.

The DIO and RQM bits in the status register indicate when data is ready and in which direction data will be transferred on the data bus. See figure 1.

Figure 1. DIO and RQM

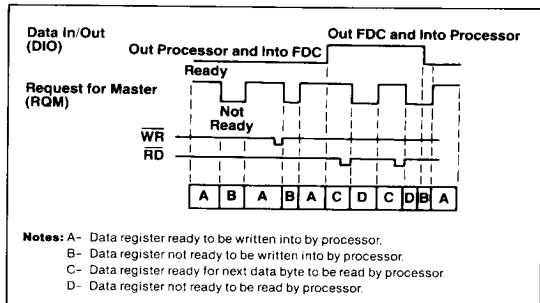

Table 3. Status Register Identification

Pin		
No.	Name	Function
Status Register 0		
D ₇ , D ₆	IC (Interrupt Code)	D ₇ = 0 and D ₆ = 0 Normal termination of command, (NT). Command was completed and properly executed. D ₇ = 0 and D ₆ = 1 Abnormal termination of command, (AT). Execution of command was started but was not successfully completed. D ₇ = 1 and D ₆ = 0 Invalid command issue, (IC). Command which was issued was never started. D ₇ = 1 and D ₆ = 1 Abnormal termination because during command execution the ready signal from FDD changed state.
D ₅	SE (Seek End)	When the FDC completes the Seek command, this flag is set to 1 (high).
D ₄	EC (Equipment Check)	If a fault signal is received from the FDD, or if the track 0 signal fails to occur after 77 step pulses (Recalibrate Command) then this flag is set.
D ₃	NR (Not Ready)	When the FDD is in the not-ready state and a Read or Write command is issued, this flag is set. If a Read or Write command is issued to side 1 of a single-sided drive, then this flag is set.
D ₂	HD (Head Address)	This flag is used to indicate the state of the head at interrupt.
D ₁	US ₁ (Unit Select 1)	This flag is used to indicate a drive unit number at interrupt.
D ₀	US ₀ (Unit Select 0)	This flag is used to indicate a drive unit number at interrupt.
Status Register 1		
D ₇	EN (End of Cylinder)	When the FDC tries to access a sector beyond the final sector of a cylinder, this flag is set.
D ₆		Not used. This bit is always 0 (low).
D ₅	DE (Data Error)	When the FDC detects a CRC(1) error in either the ID field or the data field, this flag is set.
D ₄	OR (Overrun)	If the FDC is not serviced by the host system during data transfers within a certain time interval, this flag is set.
D ₃		Not used. This bit is always 0 (low).

Table 3. Status Register Identification (cont)

Pin		
No.	Name	Function
Status Register 1 (cont)		
D ₂	ND (No Data)	During execution of Read Data, Read Deleted Data, Write Data, Write Deleted Data or Scan command, if the FDC cannot find the sector specified in the IDR(2) Register, this flag is set. During execution of the Read ID command, if the FDC cannot read the ID field without an error, then this flag is set. During execution of the Read Diagnostic command, if the starting sector cannot be found, then this flag is set.
D ₁	NW (Not Writable)	During execution of Write Data, Write Deleted Data or Write ID command, if the FDC detects a write protect signal from the FDD, then this flag is set.
D ₀	MA (Missing Address Mark)	This bit is set if the FDC does not detect the IDAM before 2 index pulses. It is also set if the FDC cannot find the DAM or DDAM after the IDAM is found. MD bit of ST2 is also set at this time.
Status Register 2		
D ₇		Not used. This bit is always 0 (low).
D ₆	CM (Control Mark)	During execution of the Read Data or Scan command, if the FDC encounters a sector which contains a deleted data address mark, this flag is set. Also set if DAM is found during Read Deleted Data.
D ₅	DD (Data Error in Data Field)	If the FDC detects a CRC error in the data field then this flag is set.
D ₄	WC (Wrong Cylinder)	This bit is related to the ND bit, and when the contents of C(3) on the medium is different from that stored in the IDR, this flag is set.
D ₃	SH (Scan Equal Hit)	During execution of the Scan command, if the condition of "equal" is satisfied, this flag is set.
D ₂	SN (Scan Not Satisfied)	During execution of the Scan command, if the FDC cannot find a sector on the cylinder which meets the condition, then this flag is set.
D ₁	BC (Bad Cylinder)	This bit is related to the ND bit, and when the contents of C on the medium is different from that stored in the IDR and the contents of C is FFH, then this flag is set.
D ₀	MD (Missing Address Mark in Data Field)	When data is read from the medium, if the FDC cannot find a data address mark or deleted data address mark, then this flag is set.

Table 3. Status Register Identification (cont)

Pin		
No.	Name	Function
Status Register 3		
D ₇	FT (Fault)	This bit is used to indicate the status of the fault signal from the FDD.
D ₆	WP (Write Protected)	This bit is used to indicate the status of the write protected signal from the FDD.
D ₅	RY (Ready)	This bit is used to indicate the status of the ready signal from the FDD.
D ₄	T0 (Track 0)	This bit is used to indicate the status of the track 0 signal from the FDD.
D ₃	TS (Two-Side)	This bit is used to indicate the status of the two-side signal from the FDD.
D ₂	HD (Head Address)	This bit is used to indicate the status of the side select signal to the FDD.
D ₁	US ₁ (Unit Select 1)	This bit is used to indicate the status of the unit select 1 signal to the FDD.
D ₀	US ₀ (Unit Select 0)	This bit is used to indicate the status of the unit select 0 signal to the FDD.

Note:

- (1) CRC = Cyclic Redundancy Check
- (2) IDR = Internal Data Register
- (3) Cylinder (C) is described more fully in the Command Symbol Description.

Command Sequence

The μPD765A/μPD765B is capable of performing 15 different commands. Each command is initiated by a multibyte transfer from the processor, and the result after execution of the command may also be a multibyte transfer back to the processor. Because of this multibyte interchange of information between the μPD765A/μPD765B and the processor, it is convenient to consider each command as consisting of three phases:

- Command Phase:** The FDC receives all information required to perform a particular operation from the processor.
- Execution Phase:** The FDC performs the operation it was instructed to do.
- Result Phase:** After completion of the operation, status and other housekeeping information are made available to the processor.

Table 4 shows the required preset parameters and results for each command. Most commands require 9 command bytes and return 7 bytes during the result phase. The "W" to the left of each byte indicates a command phase byte to be written, and an "R" indicates a result byte. The definitions of other abbreviations used in table are given in the Command Symbol Description table.

Command Symbol Description

Name	Function
A ₀ (Address Line 0)	A ₀ controls selection of main status register (A ₀ =0) or data register (A ₀ =1).
C (Cylinder Number)	C stands for the current / selected cylinder (track) numbers 0 through 76 of the medium.
D (Data)	D stands for the data pattern which is going to be written into a sector during WRITE ID operation.
D ₇ -D ₀ (Data Bus)	8-bit data bus, where D ₇ stands for a most significant bit, and D ₀ stands for a least significant bit.
DTL (Data Length)	When N is defined as 00, DTL stands for the data length which users are going to read out or write into the sector.
EOT (End of Track)	EOT stands for the final sector number on a cylinder. During read or write operations, FDC will stop data transfer after a sector number equal to EOT.
GPL (Gap Length)	GPL stands for the length of gap 3. During Read / Write commands this value determines the number of bytes that VCO sync will stay low after two CRC bytes. During Format command it determines the size of gap 3.
H (Head Address)	H stands for the logical head number 0 or 1, as specified in ID field.
HD (Head)	HD stands for a the physical head number 0 or 1 and controls the polarity of pin 27. (H=HD in all command words.)
HLT (Head Load Time)	HLT stands for the head load time in the FDD (2 to 254 ms in 2 ms increments).
HUT (Head Unload Time)	HUT stands for the head unload time after a Read or Write operation has occurred (16 to 240 ms in 16 ms increments).
MF (FM or MFM Mode)	If MF is low, FM mode is selected, and if it is high, MFM mode is selected.
MT (Multitrack)	If MT is high, a multitrack operation is performed. If MT=1 after finishing read / write operation on side 0, FDC will automatically start searching for sector 1 on side 1.
N (Number)	N stands for the number of data bytes written in a sector.
NCN (New Cylinder Number)	NCN stands for a new cylinder number which is going to be reached as a result of the seek operation; desired position of head.
ND (Non-DMA Mode)	ND stands for operation in the non-DMA mode.
PCN (Present Cylinder Number)	PCN stands for the cylinder number at the completion of Sense Interrupt Status command, position of head at present time.
R (Record)	R stands for the sector number which will be read or written.
R / W (Read / Write)	R / W stands for either Read (R) or Write (W) signal.
SC (Sector)	SC indicates the number of sectors per cylinder.
SK (Skip)	SK stands for skip deleted data address mark.

5

Command Symbol Description (cont)

Name	Function
SRT (Step Rate Time)	SRT stands for the stepping rate for the FDD (1 to 16 ms in 1 ms increments). Stepping rate applies to all drives (FH=1 ms, EH=2 ms, etc.).
ST0-ST3 (Status 0-3)	ST0-ST3 stands for one of four registers which store the status information after a command has been executed. This information is available during the result phase after command execution. These registers should not be confused with the main status register (selected by A ₀ =0). ST0-ST3 may be read only after a command has been executed and contains information relevant to that particular command.

Command Symbol Description (cont)

Name	Function
STP	During a scan operation, if STP=1, the data in contiguous sectors is compared byte by byte with data sent from the processor (or DMA); and if STP=2, then alternate sectors are read and compared.
US ₀ , US ₁ (Unit Select)	US stands for a selected drive number 0 or -3.

Table 4. Instruction Set (Notes 1, 2)

Phase	R/W	Instruction Code								Remarks
		D ₇	D ₆	D ₅	D ₄	D ₃	D ₂	D ₁	D ₀	
Read Data										
Command	W	MT	MF	SK	0	0	1	1	0	Command codes
	W	X	X	X	X	X	HD	US ₁	US ₀	(Note 3)
	W	←----- C -----→				Sector ID information prior to command execution. The 4 bytes are compared against header on floppy disk.				
	W	←----- H -----→								
	W	←----- R -----→								
	W	←----- N -----→								
	W	←----- EOT -----→								
	W	←----- GPL -----→								
W	←----- DTL -----→									
Execution										
Data transfer between the FDD and main system										
Result	R	←----- ST0 -----→				Status information after command execution				
	R	←----- ST1 -----→								
	R	←----- ST2 -----→								
	R	←----- C -----→				Sector ID information after command execution				
	R	←----- H -----→								
	R	←----- R -----→								
	R	←----- N -----→								
	Read Deleted Data									
Command	W	MT	MF	SK	0	1	1	0	0	Command codes
	W	X	X	X	X	X	HD	US ₁	US ₀	
	W	←----- C -----→				Sector ID information prior to command execution. The 4 bytes are compared against header on floppy disk.				
	W	←----- H -----→								
	W	←----- R -----→								
	W	←----- N -----→								
	W	←----- EOT -----→								
	W	←----- GPL -----→								
W	←----- DTL -----→									
Execution										
Data transfer between the FDD and main system										
Result	R	←----- ST0 -----→				Status information after command execution				
	R	←----- ST1 -----→								
	R	←----- ST2 -----→								
	R	←----- C -----→				Sector ID information after command execution				
	R	←----- H -----→								
	R	←----- R -----→								
	R	←----- N -----→								

Note:

- (1) Symbols used in this table are described at the end of this section.
- (2) A₀ should equal 1 for all operations.
- (3) X = Don't care, usually made to equal 0.

Table 4. Instruction Set (Notes 1, 2) (cont)

Phase	R/W	Instruction Code								Remarks	
		D ₇	D ₆	D ₅	D ₄	D ₃	D ₂	D ₁	D ₀		
Write Data											
Command	W	MT	MF	0	0	0	1	0	1	Command codes	
	W	X	X	X	X	X	HD	US ₁	US ₀		
	W	←				C	→				Sector ID information prior to command execution. The 4 bytes are compared against header on floppy disk.
	W	←				H	→				
	W	←				R	→				
	W	←				N	→				
	W	←				EOT	→				
	W	←				GPL	→				
	W	←				DTL	→				
	W	←					→				
Execution											
Result	R	←				ST0	→				Data transfer between the main system and FDD
	R	←				ST1	→				Status information after command execution
	R	←				ST2	→				
	R	←				C	→				Sector ID information after command execution
	R	←				H	→				
	R	←				R	→				
	R	←				N	→				
Write Deleted Data											
Command	W	MT	MF	0	0	1	0	0	1	Command codes	
	W	X	X	X	X	X	HD	US ₁	US ₀		
	W	←				C	→				Sector ID information prior to command execution. The 4 bytes are compared against header on floppy disk.
	W	←				H	→				
	W	←				R	→				
	W	←				N	→				
	W	←				EOT	→				
	W	←				GPL	→				
	W	←				DTL	→				
	W	←					→				
Execution											
Result	R	←				ST0	→				Data transfer between the FDD and main system
	R	←				ST1	→				Status information after command execution
	R	←				ST2	→				
	R	←				C	→				Sector ID information after command execution
	R	←				H	→				
	R	←				R	→				
	R	←				N	→				
Read Diagnostic											
Command	W	0	MF	SK	0	0	0	1	0	Command codes	
	W	X	X	X	X	X	HD	US ₁	US ₀		
	W	←				C	→				Sector ID information prior to command execution
	W	←				H	→				
	W	←				R	→				
	W	←				N	→				
	W	←				EOT	→				
	W	←				GPL	→				
	W	←				DTL	→				
	W	←					→				
Execution											
Result	R	←				ST0	→				Data transfer between the FDD and main system. FDC reads all data fields from index hole to EOT.
	R	←				ST1	→				Status information after command execution
	R	←				ST2	→				
	R	←				C	→				Sector ID information after command execution
	R	←				H	→				
	R	←				R	→				
	R	←				N	→				

Table 4. Instruction Set (Notes 1, 2) (cont)

Phase	R/W	Instruction Code								Remarks	
		D ₇	D ₆	D ₅	D ₄	D ₃	D ₂	D ₁	D ₀		
Read ID											
Command	W	0	MF	0	0	1	0	1	0	Command codes	
	W	X	X	X	X	X	HD	US ₁	US ₀		
Execution										The first correct ID information on the cylinder is stored in data register.	
Result	R	←				ST0	→				Status information after command execution
	R	←				ST1	→				
	R	←				ST2	→				
	R	←				C	→				Sector ID information read during execution phase from floppy disk.
	R	←				H	→				
	R	←				R	→				
	R	←				N	→				
Write ID [Format Write]											
Command	W	0	MF	0	0	1	1	0	1	Command codes	
	W	X	X	X	X	X	HD	US ₁	US ₀		
	W	←				N	→				Bytes / sector
	W	←				SC	→				Sectors / track
	W	←				GPL	→				Gap 3
	W	←				D	→				Filler byte
Execution										FDC formats an entire track.	
Result	R	←				ST0	→				Status information after command execution
	R	←				ST1	→				
	R	←				ST2	→				
	R	←				C	→				In this case, the ID information has no meaning
	R	←				H	→				
	R	←				R	→				
	R	←				N	→				
Scan Equal											
Command	W	MT	MF	SK	1	0	0	0	1	Command codes	
	W	X	X	X	X	X	HD	US ₁	US ₀		
	W	←				C	→				Sector ID information prior to command execution
	W	←				H	→				
	W	←				R	→				
	W	←				N	→				
	W	←				EOT	→				
	W	←				GPL	→				
	W	←				STP	→				
Execution										Data compared between the FDD and main system	
Result	R	←				ST0	→				Status information after command execution
	R	←				ST1	→				
	R	←				ST2	→				
	R	←				C	→				Sector ID information after command execution
	R	←				H	→				
	R	←				R	→				
	R	←				N	→				

Note:

- (1) Symbols used in this table are described at the end of this section.
- (2) A₀ should equal 1 for all operations.
- (3) X = Don't care, usually made to equal 0.

Table 4. Instruction Set (Notes 1, 2) (cont)

Phase	R/W	Instruction Code								Remarks	
		D ₇	D ₆	D ₅	D ₄	D ₃	D ₂	D ₁	D ₀		
Scan Low or Equal											
Command	W	MT	MF	SK	1	1	0	0	1	Command codes	
	W	X	X	X	X	X	HD	US ₁	US ₀		
	W	← C				→					Sector ID information prior to command execution
	W	← H				→					
	W	← R				→					
	W	← N				→					
	W	← EOT				→					
	W	← GPL				→					
	W	← STP				→					
Execution										Data compared between the FDD and main system	
Result	R	← ST0				→					Status information after command execution
	R	← ST1				→					
	R	← ST2				→					
	R	← C				→					Sector ID information after command execution
	R	← H				→					
	R	← R				→					
	R	← N				→					
Scan High or Equal											
Command	W	MT	MF	SK	1	1	1	0	1	Command codes	
	W	X	X	X	X	X	HD	US ₁	US ₀		
	W	← C				→					Sector ID information prior to command execution
	W	← H				→					
	W	← R				→					
	W	← N				→					
	W	← EOT				→					
	W	← GPL				→					
	W	← STP				→					
Execution										Data compared between the FDD and main system	
Result	R	← ST0				→					Status information after command execution
	R	← ST1				→					
	R	← ST2				→					
	R	← C				→					Sector ID information after command execution
	R	← H				→					
	R	← R				→					
	R	← N				→					
Recalibrate											
Command	W	0	0	0	0	0	1	1	1	Command codes	
	W	X	X	X	X	X	0	US ₁	US ₀		
Execution										Head retracted to track 0	
Sense Interrupt Status											
Command	W	0	0	0	0	1	0	0	0	Command codes	
Result	R	← ST0				→					Status information about the FDC at the end of seek operation
	R	← PCN				→					
Specify											
Command	W	0	0	0	0	0	0	1	1	Command codes	
	W	← SRT				← HUT					
	W	← HLT				← ND					
Sense Drive Status											
Command	W	0	0	0	0	0	1	0	0	Command codes	
	W	X	X	X	X	X	HD	US ₁	US ₀		
Result	R	← ST3 →								Status information about FDD	

Table 4. Instruction Set (Notes 1, 2) (cont)

Phase	R/W	Instruction Code								Remarks
		D ₇	D ₆	D ₅	D ₄	D ₃	D ₂	D ₁	D ₀	
Version										
Command	W	X	X	X	1	0	0	0	0	Command codes
Result	R	← ST 0 →								90H indicates 765B 80H indicates 765A / A-2
Seek										
Command	W	0	0	0	0	1	1	1	1	Command code
	W	X	X	X	X	X	HD	US ₁	US ₀	
	W	← NCN →								
Execution										Head is positioned over proper cylinder on diskette
Invalid										
Command	W	← Invalid Codes →								Invalid Command codes (No op — FDC goes into state)
Result	R	← ST 0 →								ST 0 = 80H

Note:

- (1) Symbols used in this table are described at the end of this section.
- (2) A₀ should equal 1 for all operations.
- (3) X = Don't care, usually made to equal 0.

System Configuration

Figure 2 shows an example of a system using a μPD765A/B.

Figure 2. System Configuration

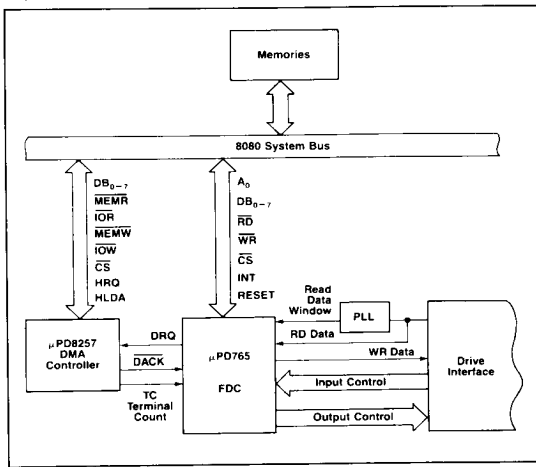

Data Format

Figure 3 shows the data transfer format for the μPD765A and μPD765B in FM and MFM modes. Figure 4 shows VCO Sync timing.

Figure 3. Data Format

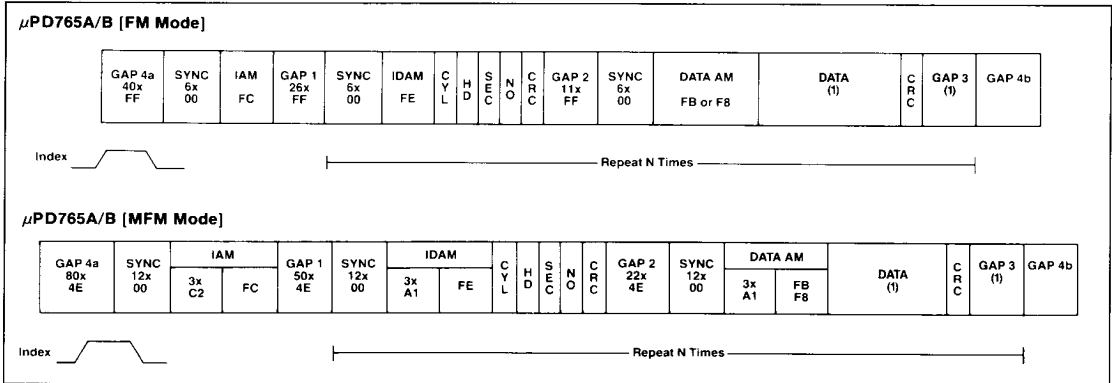

Figure 4. VCO Sync Timing

