

REV:	Initial design: R. Aiken
B	Added MOSFET circuit
C	Added MOSFET protection circuit

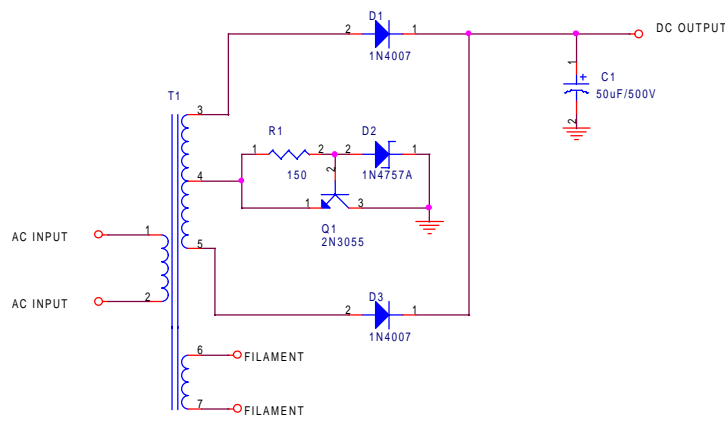

This circuit allows the use of a small (1W) zener diode and an inexpensive power transistor in place of a high-power zener diode to drop the plate voltage in a tube guitar amplifier.

The DC output is lowered by the amount of the zener voltage (50V using the diode shown) plus the forward base-emitter drop of the pass transistor (around 0.7V). Different zeners can be used for different voltage drops, but the max collector to emitter voltage rating of the 2N3055 will not allow more than 70V. To be on the safe side and not exceed ratings, 50V should be considered the maximum for this transistor. The transistor should be an NPN power transistor.

The series current limiting resistor for the zener diode should be selected to provide around 5mA or so current. This will provide decent zener action, keeping the voltage relatively constant, while not exceeding the zener power dissipation at high voltage drops. The resistor can be calculated by dividing the base-emitter voltage drop by the desired zener current. For the silicon transistor shown, the Vbe at 100mA output current is around 0.7V, so the resistor should be calculated as $R = 0.7V/5mA = 140$ ohms, therefore the nearest standard value of 150 ohms is chosen. Note that the transistor current is higher than the output current, because the capacitor is charged in pulses, rather than continuously. Also, the average zener current will be lower than this peak value, so the dissipation will be less than the product of the zener drop and the peak zener current.

The transistor must be properly heatsinked. Because the collector of the transistor is tied to the case, no isolation is necessary. The case may be mounted directly to the chassis with no isolating pads.

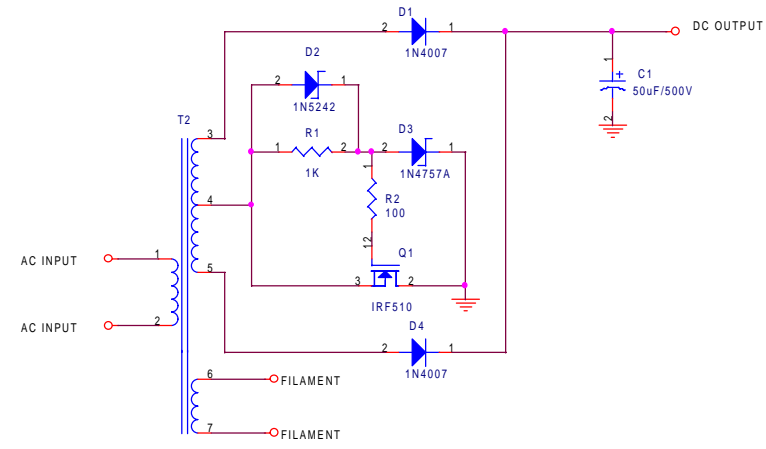

This circuit allows the use of a small (1W) zener diode and an inexpensive power MOSFET in place of a high-power zener diode to drop the plate voltage in a tube guitar amplifier.

The DC output is lowered by the amount of the zener voltage (50V using the diode shown) plus the gate-to-source drop of the MOSFET (the datasheet for the MOSFET usually gives a graph of typical gate-to-source voltages vs drain current. It will not be less than the threshold voltage). Different zeners can be used for different voltage drops, limited only by the MOSFET drain-to-source voltage rating (100V for the IRF510 MOSFET shown), and the power dissipation capability of the MOSFET. The MOSFET should be an N-channel, enhancement-mode MOSFET. These are commonly available in voltages up to 1000V. The 100V IRF510 shown is very inexpensive (currently \$0.77 from DigiKey in quantity one).

The series current limiting resistor for the zener diode should be selected to provide around 5mA or so current. This will provide decent zener action, keeping the voltage relatively constant, while not exceeding the zener power dissipation at high voltage drops. The resistor can be calculated by dividing the gate-to-source voltage drop (use the spec'd MOSFET Vgs at the current drawn) by the desired zener current. For the MOSFET shown, the Vgs at 100mA output current is around 5V, so the resistor should be calculated as $R = 5V/5mA = 1000$ ohms. Note that the MOSFET current is higher than the output current, because the capacitor is charged in pulses, rather than continuously. For the current levels in most guitar amps, it is usually safe to assume Vgs will be around a volt or two higher than the threshold voltage, Vth. Also, the average zener current will be lower than this value, so the power dissipation will be less than the product of the zener voltage and this peak current.

The MOSFET must be properly heatsinked. Because the drain of the MOSFET is tied to the case, no isolation is necessary. The case may be mounted directly to the chassis with no isolating pads.

The zener diode across the MOSFET gate-to-source terminals is for overvoltage or surge protection of the device. The 100 ohm gate resistor is to damp any oscillation tendencies.

Note:
These circuits are an adaptation of the circuit originally provided by Marc Meyer.

AIKEN AMPLIFICATION		
Duluth, GA 30096		
Tel: 770-279-2492		
Fax: 770-279-9189		
Title	Lowering plate voltage using a power transistor	
Size	Document Number	Rev C
Date:	Wednesday, December 15, 1999	Sheet 1 of 1